

Pressure switch Models 201, 203, 281

WIKA data sheet PV 35.54

Applications

- Hydraulics and pneumatics
- Steel
- Power
- Special purpose machine

Special features

- Internal Switch point adjustment for critical applications
- Stainless steel case option for corrosive environment
- Switch point repeatability of $\pm 0.5\%$ of FSR for reliable switching
- Two set-point option for controlling at different process levels



Fig. Left: Pressure switch, model 201, weatherproof
Fig. Right: Pressure switch, model 201, flameproof

Description

Series 200 Pressure Switches is a SWITZER mainstream product range for switching upto 75 bar and includes models for vacuum, compound and millibar ranges and high overload protection.

Precision mechanisms are of stainless steel for Hazardous atmospheres and high humidity. Enclosures, sensing elements and switching modes can be combined to offer the variety needed to suit the demands of rapidly expanding industrial processes.

Precise and accurate operation is obtained by using time proven seamless hydraulically formed bellows. Setpoint is continuously adjustable over the instrument range. A scale is provided for approximate switch setting.

Specifications

| Basic information | |
|-------------------|------------------------------------------------------------------------------------------------------------------------------------------------------------------------------------------------------------------------------------------------------------------------------------------------------------------------------------------------------------------------------------------------------------------------------------------------------------------------------------------------------------------------------------------------------------------|
| Switch enclosure | <ul style="list-style-type: none"> ■ GM style aluminium pressure die cast weatherproof to IP66 with nitrile gasket ■ GA style 304 SS casting, weatherproof to IP66, fit for off shore ■ GA6 style 316 SS casting, weatherproof to IP66, fit for off shore ■ GK style aluminium pressure die cast, weatherproof and flameproof to group IIC as per IS/IEC 60079-1 ■ GR style aluminium pressure die cast, weatherproof to IP66 and flameproof to group IIC as per IS/IEC 60079-1 (available only in model 201) |
| Sealing | Nitrile |
| Measuring element | 316L SS bellows |
| Wetted parts | 316L SS |

| Output signal | |
|----------------------------------------|------------------------------------------------------------------------------------------------------------------------------------------------------|
| Ranges | Several ranges from -1 ... +75 bar |
| Switching differential | <ul style="list-style-type: none"> ■ Fixed ■ Wideband adjustable |
| Repeatability of the setpoint (note 3) | <ul style="list-style-type: none"> ■ $\pm 0.5\%$ of FSR for 201 & 203 ■ $\pm 1.0\%$ of FSR for 281 |
| Maximum working pressure | Refer table 1 |
| Scale accuracy (note 4) | $\pm 5\%$ of FSR |
| Switching contacts with microswitch | <ul style="list-style-type: none"> ■ 1 x SPDT (single pole double throw) ■ 2 x SPDT (single pole double throw) |
| Switching function (note 8) | Instrument quality snap acting microswitch |

| Operating condition | |
|---------------------------------|-----------------------------------------------------------------------------------------------------------------|
| Permissible ambient temperature | -10°C ... +60°C |
| Permissible medium temperature | 170°C for bellows |
| Ingress protection | IP66 |
| Process connection | 1/4" NPT(F) per ASME B1.20.1 direct Other connections through adaptor |
| Electrical connection | 1/2" NPT(F) per ASME B1.20.1 single entry standard Dual entry on request |
| Mounting | <ul style="list-style-type: none"> ■ Panel ■ Wall ■ On-line ■ 2" pipe |

Ordering matrix

Sample model number

GM 201 02 B02 CE

Switch enclosure

- GM style aluminium pressure die cast weatherproof to IP66 with nitrile gasket GM
- GA style 304 SS casting, weatherproof to IP66, fit for off shore GA
- GA style 316 SS casting, weatherproof to IP66, fit for off shore GA6
- GK style aluminium pressure die cast, weatherproof and flameproof to group IIC as per IS/IEC 60079-1 GK
- GR style aluminium pressure die cast, weatherproof to IP66 and flameproof to group IIC as per IS/IEC 60079-1 (available only in model 201) GR

Model

- This is the basic pressure switch actuated by a seamless bellows having close fixed non-adjustable switching differential. 201
- Same as 201, but with auxiliary mechanism permitting switching differential adjustment between 8–15% min. to 60% max. without disturbing the falling set point. 203
- A variant of series 200, employs twin levers each operating a SPDT microswitch actuated by a single sensor through a unique linkage thereby providing two independent adjustable setpoints, each with its own setting scale, spring and switch. Minimum separation between setpoints must be more than sum of on-off differentials; or 10% of FSR whichever is higher. 281

Sensor material

- 316L SS bellows 3

Wetted part

- 316L SS 3

Range code

- Refer table-1

Switch code and rating

- Refer table-6

Electrical entry code

- Refer table-7

Option

- CE conformity (not applicable for GR enclosure) CE

For available other options refer table-8

Table 1: Range code and availability

| Range code | Range | 201 | 203 | 281 | Maximum working pressure bar |
|-------------|-----------------------------------------|-----|-----|-----|------------------------------|
| B001 / K087 | - 1 ... 0 bar / Kg/Cm ² | ✓ | ✓ | ✗ | 4 |
| B003 / K007 | - 0.5 ... +0.5 bar / Kg/Cm ² | ✓ | ✓ | ✗ | 4 |
| B002 / K078 | - 1 ... +1.5 bar / Kg/Cm ² | ✓ | ✓ | ✗ | 4 |
| M041 | 5 ... 50 mbar | ✓ | ✗ | ✗ | 2 |
| M045 | 7.5 ... 75 mbar | ✓ | ✗ | ✗ | 2 |
| M046 | 10 ... 100 mbar | ✓ | ✗ | ✗ | 2 |
| M043 | 5 ... 200 mbar | ✓ | ✗ | ✗ | 2 |
| M044 | 5 ... 250 mbar | ✓ | ✗ | ✗ | 2 |
| B020 / K088 | 0.05 ... 0.16 bar | ✓ | ✓ | ✗ | 2 |
| B021 / K089 | 0.08 ... 0.4 bar / Kg/Cm ² | ✓ | ✓ | ✓ | 4 |
| B022 / K091 | 0.1 to 1.1 bar / Kg/Cm ² ★ | ✓ | ✓ | ✓ | 4 |
| B027 / K092 | 0.2 ... 2 bar / Kg/Cm ² ★ | ✓ | ✓ | ✓ | 4 |
| B030 / K093 | 0.4 ... 4 bar / Kg/Cm ² ★ | ✓ | ✓ | ✓ | 8 |
| B031 / K094 | 0.6 ... 6 bar / Kg/Cm ² ★ | ✓ | ✓ | ✓ | 9 |
| B033 / K095 | 1 ... 10 bar / Kg/Cm ² ★ | ✓ | ✓ | ✓ | 15 |
| B035 / K096 | 1.6 ... 16 bar / Kg/Cm ² ★ | ✓ | ✓ | ✓ | 25 |
| B036 / K097 | 2 ... 20 bar / Kg/Cm ² ★ | ✓ | ✓ | ✓ | 25 |
| B038 / K098 | 8 ... 32 bar / Kg/Cm ² ★ | ✓ | ✓ | ✓ | 36 |
| B039 / K076 | 10 ... 40 bar / Kg/Cm ² ★ | ✓ | ✓ | ✓ | 50 |
| B040 / K099 | 10 ... 60 bar / Kg/Cm ² ★ | ✓ | ✓ | ✓ | 80 |
| B041 / K100 | 15 ... 75 bar / Kg/Cm ² ★ | ✓ | ✓ | ✗ | 80 |
| W037 | 50 ... 500 mmWC | ✓ | ✗ | ✗ | 2 |
| W173 | 75 ... 750 mmWC | ✓ | ✗ | ✗ | 2 |
| W038 | 100 ... 1000 mmWC | ✓ | ✗ | ✗ | 2 |
| W174 | 50 ... 2000 mmWC | ✓ | ✗ | ✗ | 2 |
| W186 | 50 ... 2500 mmWC | ✓ | ✗ | ✗ | 2 |

★ Chemical seal options available, See datasheet DS 70.01. For SPDT function, the minimum switching differential shall be arrived by applying 1.3 multiplication factor to values given in differential Table. For DPDT function, the minimum switching differential shall be arrived by applying 1.5 multiplication factor to values given in differential Tables '2, 3, 4 & 5'.

Table 2: Switching differential for model 201, GM / GA enclosure

| Range code | Range | Unit | Switching differential for contact versions - GM/GA Enclosures | | | | | |
|-------------|----------------|--------------------------|----------------------------------------------------------------|-------|-------|------------|-------|--------|
| | | | D, 3, 4 | 5 | 9, G | DD, 33, 44 | 55 | 99, GG |
| B001 / K087 | - 1 ... 0 | bar / Kg/Cm ² | 0.04 | 0.07 | 0.12 | 0.052 | 0.09 | 0.155 |
| B003 / K007 | - 0.5 ... +0.5 | bar / Kg/Cm ² | 0.04 | 0.07 | 0.12 | 0.052 | 0.09 | 0.155 |
| B002 / K078 | - 1 ... +1.5 | bar / Kg/Cm ² | 0.045 | 0.075 | 0.15 | 0.059 | 0.1 | 0.195 |
| M041 | 5 ... 50 | mbar | 5 | 6 | 10 | 7 | 8 | 13 |
| M045 | 7.5 ... 75 | mbar | 5 | 6 | 10 | 7 | 8 | 13 |
| M046 | 10 ... 100 | mbar | 8 | 8 | 12 | 11 | 10 | 16 |
| M043 | 5 ... 200 | mbar | 10 | 10 | 15 | 13 | 12 | 20 |
| M044 | 5 ... 250 | mbar | 10 | 10 | 15 | 13 | 12 | 20 |
| B020 / K088 | 0.05 ... 0.16 | bar / Kg/Cm ² | 0.01 | 0.008 | 0.015 | 0.013 | 0.01 | 0.02 |
| B021 / K089 | 0.08 ... 0.4 | bar / Kg/Cm ² | 0.012 | 0.016 | 0.025 | 0.013 | 0.021 | 0.032 |
| B022 / K091 | 0.1 ... 1.1 | bar / Kg/Cm ² | 0.02 | 0.03 | 0.05 | 0.026 | 0.04 | 0.065 |
| B027 / K092 | 0.2 ... 2 | bar / Kg/Cm ² | 0.025 | 0.04 | 0.08 | 0.033 | 0.05 | 0.104 |
| B030 / K093 | 0.4 ... 4 | bar / Kg/Cm ² | 0.06 | 0.098 | 0.18 | 0.078 | 0.128 | 0.234 |
| B031 / K094 | 0.6 ... 6 | bar / Kg/Cm ² | 0.075 | 0.12 | 0.27 | 0.098 | 0.156 | 0.351 |
| B033 / K095 | 1 ... 10 | bar / Kg/Cm ² | 0.075 | 0.17 | 0.2 | 0.098 | 0.22 | 0.26 |
| B035 / K096 | 1.6 ... 16 | bar / Kg/Cm ² | 0.15 | 0.22 | 0.3 | 0.195 | 0.3 | 0.39 |
| B036 / K097 | 2 ... 20 | bar / Kg/Cm ² | 0.2 | 0.25 | 0.5 | 0.26 | 0.35 | 0.65 |
| B038 / K098 | 8 ... 32 | bar / Kg/Cm ² | 0.25 | 0.35 | 0.6 | 0.325 | 0.455 | 0.78 |
| B039 / K076 | 10 ... 40 | bar / Kg/Cm ² | 0.3 | 0.4 | 0.7 | 0.39 | 0.52 | 0.91 |
| B040 / K099 | 10 ... 60 | bar / Kg/Cm ² | 0.5 | 0.9 | 1.4 | 0.65 | 1.17 | 1.82 |
| B041 / K100 | 15 ... 75 | bar / Kg/Cm ² | 0.6 | 0.96 | 2 | 0.78 | 1.25 | 2.6 |
| W037 | 50 ... 500 | mmWC | 50 | 60 | 100 | 70 | 80 | 130 |
| W173 | 75 ... 750 | mmWC | 80 | 80 | 120 | 110 | 80 | 160 |
| W038 | 100 ... 1000 | mmWC | 80 | 80 | 120 | 79 | 100 | 130 |
| W174 | 50 ... 2000 | mmWC | 100 | 100 | 150 | 130 | 120 | 200 |
| W186 | 50 ... 2500 | mmWC | 100 | 100 | 150 | 130 | 120 | 200 |

Table 3: Switching differential for model 201, GR / GK enclosure

| Range code | Range | Unit | Switching differential for contact versions - GR/GK Enclosures | | | | | |
|-------------|----------------|--------------------------|----------------------------------------------------------------|-------|-------|------------|-------|--------|
| | | | D, 3, 4 | 5 | 9,G | DD, 33, 44 | 55 | 99, GG |
| B001 / K087 | - 1 ... 0 | bar / Kg/Cm ² | 0.07 | 0.1 | 0.19 | 0.084 | 0.12 | 0.228 |
| B003 / K007 | - 0.5 ... +0.5 | bar / Kg/Cm ² | 0.07 | 0.1 | 0.19 | 0.084 | 0.12 | 0.228 |
| B002 / K078 | - 1 ... +1.5 | bar / Kg/Cm ² | 0.08 | 0.13 | 0.245 | 0.096 | 0.156 | 0.294 |
| M041 | 5 ... 50 | mbar | 8 | 9 | 14 | 9.6 | 10.8 | 17 |
| M045 | 7.5 ... 75 | mbar | 8 | 9 | 16 | 9.6 | 9.6 | 19.2 |
| M046 | 10 ... 100 | mbar | 12 | 12 | 18 | 14.4 | 14.4 | 21.6 |
| M043 | 5 ... 200 | mbar | 15 | 15 | 20 | 18 | 18 | 24 |
| M044 | 5 ... 250 | mbar | 15 | 15 | 20 | 18 | 18 | 24 |
| B020 / K088 | 0.05 ... 0.16 | bar / Kg/Cm ² | 0.015 | 0.015 | 0.02 | 0.018 | 0.018 | 0.024 |
| B021 / K089 | 0.08 ... 0.4 | bar / Kg/Cm ² | 0.018 | 0.024 | 0.035 | 0.022 | 0.029 | 0.042 |
| B022 / K091 | 0.1 ... 1.1 | bar / Kg/Cm ² | 0.03 | 0.04 | 0.1 | 0.036 | 0.048 | 0.12 |
| B027 / K092 | 0.2 ... 2 | bar / Kg/Cm ² | 0.04 | 0.05 | 0.135 | 0.048 | 0.06 | 0.162 |
| B030 / K093 | 0.4 ... 4 | bar / Kg/Cm ² | 0.1 | 0.15 | 0.27 | 0.12 | 0.18 | 0.324 |
| B031 / K094 | 0.6 ... 6 | bar / Kg/Cm ² | 0.125 | 0.195 | 0.405 | 0.15 | 0.234 | 0.486 |
| B033 / K095 | 1 ... 10 | bar / Kg/Cm ² | 0.175 | 0.3 | 0.3 | 0.21 | 0.36 | 0.36 |
| B035 / K096 | 1.6 ... 16 | bar / Kg/Cm ² | 0.26 | 0.325 | 0.45 | 0.312 | 0.39 | 0.54 |
| B036 / K097 | 2 ... 20 | bar / Kg/Cm ² | 0.3 | 0.375 | 0.75 | 0.36 | 0.45 | 0.9 |
| B038 / K098 | 8 ... 32 | bar / Kg/Cm ² | 0.36 | 0.5 | 0.9 | 0.432 | 0.60 | 1.08 |
| B039 / K076 | 10 ... 40 | bar / Kg/Cm ² | 0.525 | 0.525 | 1 | 0.63 | 0.63 | 1.2 |
| B040 / K099 | 10 ... 60 | bar / Kg/Cm ² | 0.85 | 1.2 | 2 | 1.02 | 1.44 | 2.4 |
| B041 / K100 | 15 ... 75 | bar / Kg/Cm ² | 1 | 1.5 | 2.8 | 1.2 | 1.8 | 3.36 |
| W037 | 50 ... 500 | mmWC | 80 | 90 | 140 | 100 | 100 | 170 |
| W173 | 75 ... 750 | mmWC | 80 | 90 | 160 | 96 | 144 | 192 |
| W038 | 100 ... 1000 | mmWC | 120 | 120 | 180 | 144 | 144 | 216 |
| W174 | 50 ... 2000 | mmWC | 150 | 150 | 200 | 180 | 180 | 240 |
| W186 | 50 ... 2500 | mmWC | 150 | 150 | 200 | 180 | 180 | 240 |

Table 4: Switching differential for model 203

| Range code | Range | Unit | Switching differential for contact versions GM / GA Enclosures | | Switching differential for contact versions GK Enclosures | |
|-------------|----------------|--------------------------|----------------------------------------------------------------|---------------|-----------------------------------------------------------|--------------|
| | | | W | WW | W | WW |
| B001 / K087 | - 1 ... 0 | bar / Kg/Cm ² | 0.175 ... 0.6 | 0.23 ... 0.6 | 0.3 ... 0.6 | 0.36 ... 0.6 |
| B003 / K007 | - 0.5 ... +0.5 | bar / Kg/Cm ² | 0.175 ... 0.5 | 0.23 ... 0.5 | 0.3 ... 0.5 | 0.36 ... 0.5 |
| B002 / K078 | - 1 ... +1.5 | bar / Kg/Cm ² | 0.2 ... 1 | 0.26 ... 1 | 0.35 ... 1 | 0.42 ... 1 |
| B021 / K089 | 0.08 ... 0.4 | bar / Kg/Cm ² | 0.05 ... 0.15 | 0.07 ... 0.15 | 0.08 ... 0.15 | 0.1 ... 0.15 |
| B022 / K091 | 0.1 ... 1.1 | bar / Kg/Cm ² | 0.08 ... 0.6 | 0.1 ... 0.6 | 0.14 ... 0.6 | 0.17 ... 0.6 |
| B027 / K092 | 0.2 ... 2 | bar / Kg/Cm ² | 0.15 ... 1.2 | 0.2 ... 1.2 | 0.25 ... 1.2 | 0.3 ... 1.2 |
| B030 / K093 | 0.4 ... 4 | bar / Kg/Cm ² | 0.5 ... 2.5 | 0.65 ... 2.4 | 0.8 ... 2.4 | 0.96 ... 2.4 |
| B031 / K094 | 0.6 ... 6 | bar / Kg/Cm ² | 0.8 ... 3.6 | 1.05 ... 3.6 | 1.3 ... 3.6 | 1.56 ... 3.6 |
| B033 / K095 | 1 ... 10 | bar / Kg/Cm ² | 0.5 ... 6 | 0.65 ... 6 | 0.85 ... 6 | 1 ... 6 |
| B035 / K096 | 1.6 ... 16 | bar / Kg/Cm ² | 1.2 ... 10 | 1.56 ... 10 | 2 ... 10 | 2.4 ... 10 |
| B036 / K097 | 2 ... 20 | bar / Kg/Cm ² | 1.3 ... 12 | 1.7 ... 12 | 2.2 ... 12 | 2.65 ... 12 |
| B038 / K098 | 8 ... 32 | bar / Kg/Cm ² | 1.8 ... 18 | 2.35 ... 18 | 2.8 ... 18 | 3.35 ... 18 |
| B039 / K076 | 10 ... 40 | bar / Kg/Cm ² | 2.5 ... 24 | 3.25 ... 24 | 4.3 ... 24 | 5.5 ... 24 |
| B040 / K099 | 10 ... 60 | bar / Kg/Cm ² | 4 ... 36 | 5.2 ... 36 | 6.8 ... 36 | 8.0 ... 36 |
| B041 / K100 | 15 ... 75 | bar / Kg/Cm ² | 8 ... 40 | 10.4 ... 40 | 13.5 ... 40 | 16 ... 40 |

Table 5: Switching differential for model 281

| Range code | Range | Unit | Switching differential for contact versions GM / GA Enclosures | | | Switching differential for contact versions GK Enclosures | | |
|-------------|--------------|--------------------------|----------------------------------------------------------------|-------|------|-----------------------------------------------------------|-------|-------|
| | | | D, 3, 4 | 5 | 9, G | D, 3, 4 | 5 | 9, G |
| B021 / K089 | 0.08 ... 0.4 | bar / Kg/Cm ² | 0.015 | 0.03 | 0.05 | 0.02 | 0.038 | 0.085 |
| B022 / K091 | 0.1 ... 1.1 | bar / Kg/Cm ² | 0.03 | 0.055 | 0.1 | 0.055 | 0.08 | 0.15 |
| B027 / K092 | 0.2 ... 2 | bar / Kg/Cm ² | 0.04 | 0.065 | 0.15 | 0.055 | 0.08 | 0.215 |
| B030 / K093 | 0.4 ... 4 | bar / Kg/Cm ² | 0.09 | 0.18 | 0.3 | 0.125 | 0.233 | 0.435 |
| B031 / K094 | 0.6 ... 6 | bar / Kg/Cm ² | 0.11 | 0.233 | 0.45 | 0.16 | 0.3 | 0.645 |
| B033 / K095 | 1 ... 10 | bar / Kg/Cm ² | 0.15 | 0.31 | 0.5 | 0.21 | 0.4 | 0.475 |
| B035 / K096 | 1.6 ... 16 | bar / Kg/Cm ² | 0.225 | 0.42 | 0.51 | 0.315 | 0.55 | 0.715 |
| B036 / K097 | 2 ... 20 | bar / Kg/Cm ² | 0.25 | 0.45 | 0.85 | 0.35 | 0.6 | 1.2 |
| B038 / K098 | 8 ... 32 | bar / Kg/Cm ² | 0.35 | 0.72 | 1.1 | 0.5 | 1 | 1.53 |
| B039 / K076 | 10 ... 40 | bar / Kg/Cm ² | 0.45 | 0.77 | 1.2 | 0.63 | 1.5 | 1.665 |
| B040 / K099 | 10 ... 60 | bar / Kg/Cm ² | 0.75 | 1.5 | 2.4 | 1 | 1.9 | 3.3 |

Table 6: Switch code, rating and availability (note 9)

| Switch code | | Contact version | AC rating | DC rating in Ampere | | | | | | Availability in models | |
|-------------|------|------------------------------------------------------------------|-----------------|---------------------|------|-------|-----------|------|--------|------------------------|------|
| SPDT | DPDT | | | Resistive | | | Inductive | | | SPDT | DPDT |
| | | | | 250V | 125V | 30V | 250V | 125V | 30V | | |
| D | DD | General purpose | 15A 250 / 125V | 0.2 | 0.4 | 2.0 | 0.02 | 0.03 | 1.0 | 201 & 281 | 201 |
| 3 | 33 | General purpose | 15A 250 / 125V | - | - | - | - | - | - | 201 & 281 | 201 |
| W | WW | General purpose | 15A 250 / 125V | - | - | - | - | - | - | 203 | 203 |
| 4 | 44 | With Gold alloy contact. | 1A 125V | - | 0.5 | 0.5 | - | 0.25 | 0.25 | 201 & 281 | 201 |
| 5 | 55 | General purpose with good DC rating. | 5A 250 / 125V | 0.2 | 0.4 | 4.0 | 0.2 | 0.4 | 3.0 | 201 & 281 | 201 |
| 9 | 99 | Hermetically sealed, inert gas filled with Silver alloy contact. | 1A 115V 400 Hz. | - | - | 3.0 * | - | - | 1.0 * | 201 & 281 | 201 |
| G | GG | Hermetically sealed, inert gas filled with Gold plated contact. | - | - | - | 1.0 * | - | - | 0.25 * | 201 & 281 | 201 |

Note : In model 281 DPDT for individual set point is not available,
 For model 281 specify only one character for switch code D, 4, etc
 * For Codes 9, 99, G, GG; DC Rating of Resistive and Inductive is 28V

Table 7: Electrical entry

| Size * | Single entry | | Dual entry | |
|----------------------------------------------|--------------|-------|------------|-------|
| | GM / GA | GK/GR | GM / GA | GK/GR |
| 1/2" NPT(F) per ASME B1.20.1 | A | A | N | N |
| 3/4" NPT(F) per ASME B1.20.1 through adaptor | L | - | O | - |
| M20 x 1.5 per ISO724 ** | E | E | EB | EB |
| 7 pin plug through connector *** | C | - | - | - |
| 9 pin plug through connector | D | - | - | - |

* Cable gland available on request
 ** Possible in GK and GR enclosure as direct. Others through adaptor.
 *** Possible only in GM enclosure.

Table 8: Options

| Details | Model | | |
|---------------------------------------------------|-------|-----|-----|
| | 201 | 203 | 281 |
| Chemical Seal | ✓ | ✓ | # |
| Special Range | ✓ | ✓ | ✓ |
| Zero Starting § | ✓ | ✓ | NP |
| Optional MWP # | ✓ | ✓ | NP |
| PVC Cover for Armour of chemical seal | ✓ | ✓ | # |
| Full Vacuum withstandability | ✓ | ✓ | NP |
| Ammonia Service | ✓ | ✓ | NP |
| Oxygen Service | ✓ | ✓ | ✓ |
| Nuclear Service | ✓ | ✓ | ✓ |
| EPDM cover gasket (only for GM / GA / GR) | ✓ | ✓ | ✓ |
| NACE Preparation ★ | ✓ | ✓ | ✓ |
| Blow out disc (not available in GR) | ✓ | ✓ | ✓ |
| Special repeatability | NP | NP | ✓ |
| Optional scale accuracy ±2% (not available in GR) | ✓ | ✓ | ✓ |

NP Not possible

Consult sales department

★ Available only with '316L SS' wetted parts

§ Available only in M041, M045, M046, M043, M044, B020, B021, B022, B027, B030, B031, B033.
Chemical seal is not possible with zero starting.

NOTES

1. Style GM/GA is weatherproof only if all entries and joint faces are properly sealed. Style GK / GR is weatherproof only if cover 'O' ring is retained in position and flameproof only if proper FLP cable gland is used. It is recommended to procure cable glands along with GK / GR instruments to avoid neglect of it while installation.
2. Intrinsic Safety (Exi) — Pressure switches are classified as simple apparatus as they neither generate nor store energy. Hence pressure switches in weatherproof (GM/ GA) enclosures also may be used in intrinsically safe systems without certification provided the power source is certified IS. Because of the low voltages and currents it is recommended to use gold contact and / or sealed contacts.
3. Accuracy & Repeatability are not different for all blind pressure switches. A shift of $\pm 2\%$ may be observed in setpoint when pressure falls from full static pressure. Settings will also shift with varying temperature.
4. The instrument is calibrated in the mounting position depicted in the drawing. Mounting in any other direction will cause a minor range shift, especially in low and compound ranges. Ranges above 1 bar will not experience this shift.
5. A pressure switch is a switching device and not a measuring instrument — eventhough it has a scale to assist setting. For this reason, Test Certificates will not contain individual ON-OFF switching values at different scale readings. Maximum differential obtained alone will be declared, besides other specifications.
6. Select working range of the instrument such that the set value lies in the mid 35% of the range i.e., between 35% and 70% of range span.
7. For switching differential values refer differential tables. Switching differentials furnished are nominal values under test conditions at mid-scale and will vary with range settings and operating conditions.
8. On and off settings should not exceed the upper or lower range value.
9. DPDT action is achieved by two SPDT switches synchronised to practical limits i.e., $\pm 2\%$ of FSR. Deadband for DPDT contacts are higher than that of SPDT as force required to actuate the contacts are more. Please refer respective range table for exact values.
10. Contact life of microswitches are 5×10^5 switching cycles for nominal load. To quench DC sparks, use diode in parallel with inductance, ensuring polarity. A 'R-C' network is also recommended with 'R' value in Ohms equal to coil resistance and 'C' value in micro Farads equal to holding current in Amps.
11. Higher Maximum Working Pressure is available on request for some ranges; but ON-OFF differentials will be higher.
12. Ambient temperature range: All models are suitable for operating within a range of ambient temperature from (-) 10°C to (+) 60°C provided the process does not freeze within this range. Below 0°C , precautions should be taken in humid atmospheres to prevent frost formation inside the instrument from jamming the mechanism. Occasional excursions beyond this range are possible but accuracy might be impaired. The microswitch is the limiting factor which should never exceed the limits (-) 50°C to (+) 80°C .
13. Fluid Temperature: A pressure switch when connected to the process is not subjected to through flow and therefore is not fully exposed to the fluid temperature. Use of adequate length of impulse piping will greatly reduce excessive heating of the sensing element. For e.g., connection of 7.5 cm of 12 mm dia impulse piping will reduce water temperature of 100°C to 65°C at an ambient temperature of 50°C . Ask factory for piping nomogram #441184-4 for different temperatures.
14. Ensure that impulse pipework applies no stress on sensing element housing and use spanners to hold pressure port/ housing when connections are made.
15. For pressure above 75 bar, Switzer S20/920 Series and PS01 Series are available. Complementary instrumentation for differential pressure is available in Series 300.
16. Custom built instruments are available for special service requirements under Special Engineering Category.
17. Accuracy figures are exclusive of test equipment tolerance on the claimed values.
18. All performance data are guaranteed to $\pm 5\%$.

Dimensions in mm

Models 201, 203 & 281 in GM enclosure

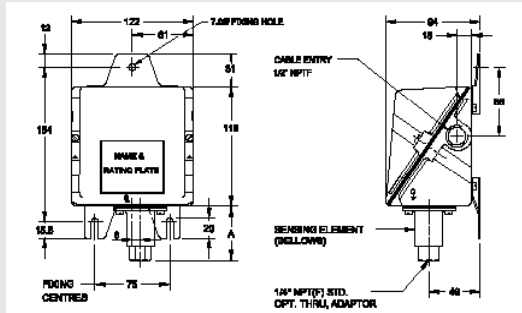

Dim 'A' varies from 42 to 92^{±2} depending on range

Models 201, 203 & 281 in GK enclosure

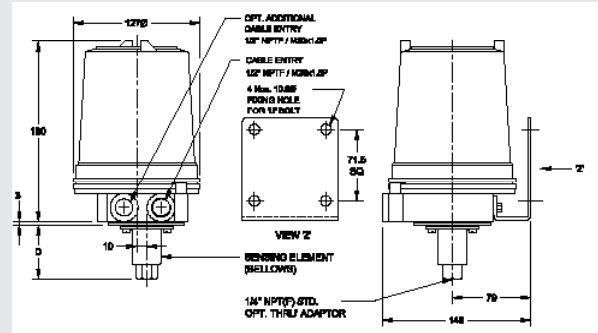

Dim 'D' varies from 42 to 92^{±2} depending on range

Models 201 in GR enclosure

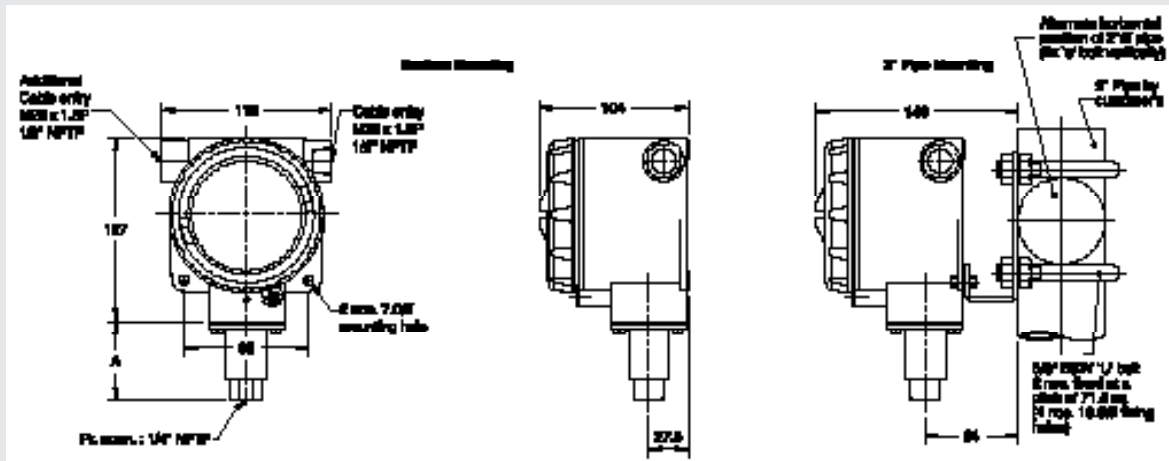

Dim 'A' varies from 42 to 92^{±2} depending on range

Note: Unspecified general tolerance ± 1

Ordering information

Switch enclosure / Model / Sensor material / Wetted part / Range code / Switch code and rating / Electrical entry code

© 2022 WIKA Alexander Wiegand SE & Co. KG, all rights reserved.
The specifications given in this document represent the state of engineering at the time of publishing.
We reserve the right to make modifications to the specifications and materials.

